

ECARO-25® VALUABLE ASSET FIRE PROTECTION

INTRODUCTION

ECARO-25 together with Fike's rapid detection and control equipment, provides the superior level of protection necessary for high-value assets and businesses that can't afford business interruption, downtime or loss in revenue as a result of a fire. ECARO-25 extinguishes fires at the molecular level, without reducing the oxygen supply of the protected space. It extinguishes fires by absorbing heat and interrupting the combustion reaction so a fire cannot sustain itself. Fires are quickly detected and extinguished before damage from smoke or flames can occur. Because oxygen levels are not effected by ECARO-25 (HFC-125), it poses no threat to people, even those present at the time of discharge.

APPLICATIONS

ECARO-25 is a total flood fire extinguishing system designed to protect Class-A fires for normally occupied spaces. Class-A fire assets represent greater than 90% of all applications. Typical applications include computer rooms, data storage, telecommunication switch stations, semi-conductor manufacturing facilities, clean rooms, libraries, museums, and historical sites.

The extinguishing agent utilized in ECARO-25 is HFC-125 (DuPont™ FE-25™), which is an environmentally acceptable replacement for Halon due to its zero ozone depletion potential, low global warming potential and short atmospheric lifetime. It is particularly useful where an environmentally acceptable agent is essential, where clean-up of other media presents a problem, where weight versus suppression potential is a factor, where an electrically non-conductive medium is needed, and where people compatibility is an overriding factor.

THE PROBLEM: DOWNTIME

A fire can destroy assets and it is highly likely a business that suffers a significant fire will never re-open. Relying on water-based systems for fire protection will meet your primary objective, which is to protect life and physical property. However, it will not protect the continuity of business or your information. Due to the speed of detection and suppression of a water-based system, a fire has more time to develop and grow. The damage caused by a developed fire in terms of smoke and combustion pollutants can be substantial. A water-based system can cause substantial water damage as well. Water can cause electrical surge and shock damage to sensitive equipment. A water-based system can do as much physical damage from water as a fire, especially to high-value electronic equipment, documents, and assets. Recovering from a fire condition where a water-based system is relied upon is time-consuming and translates into a significant business interruption.

THE SOLUTION: ECARO-25

ECARO-25 possesses many physical properties which make it desirable as a asset fire protection system. Unlike traditional water-based sprinkler systems, ECARO-25 is non-conductive, non-corrosive, and leaves no residue, so it will not damage high-value assets or electrical components or pose a clean up problem. Since ECARO-25 is discharged as a gaseous vapor, it rapidly penetrates enclosures to get to the source of the fire, reaching areas that water or dry chemical agent cannot.

The quantity of ECARO-25 agent is accurately calculated for each risk area, and installation of the system is carried out with storage containers connected to a common manifold and pipe network delivering the agent to strategically placed nozzles. The Fike rupture disc valve design, cylinder volume and pressure, together with the pipe network and calculated discharge nozzles ensure that ECARO-25 agent is released and distributed evenly throughout the protected space(s).

ECARO-25 uses unique mechanisms to prevent or extinguish a fire compared to conventional extinguishing agents such as water, dry chemical and carbon dioxide, which are unacceptable because they may cause collateral damage, significantly interrupt business productivity or present a safety risk. The unique mechanism ECARO-25 relies upon is its ability to absorb, at a molecular level, the heat energy from the combustion reaction. The ability of ECARO-25 to absorb heat faster than the amount of heat generated by the combustion reaction essentially ceases the combustion reaction since it cannot sustain itself. The ability of ECARO-25 to form free radicals, which chemically interfere with the chain reaction of the combustion process, also aids in the extinction of the fire.

Form No. CAAP 040

SELECTING A LONG TERM CLEAN AGENT SYSTEM

It is important that a clean agent system is selected that will present a long lifetime and not force the end-user to replace their fire protection system. The ECARO-25 system has the lowest environmental impact of any of the HFC products, which have been commercialized in the fire protection industry. The ECARO-25 system supplies the best combination of benefits to the end-user from an environmental and commercial perspective. ECARO-25 is also a significant component of many of the refrigeration blends being used today to replace CFCs. In total, the benefits of the ECARO-25 system and its utility in many applications make it a long-term solution in the fire protection industry.

The Fike ECARO-25 system has received system approval by Factory Mutual Research Corporation (FM), Underwriters Laboratory (UL) and is included in NFPA 2001 and ISO 14520. In addition, Dupont FE-25 fire extinguishing agent has been validated by independent agencies and received component approval from UL and FM. FE-25 is listed as an acceptable replacement for Halon 1301 in the United States Environment Protection Agency's Significant New Alternative Policy (SNAP) program and Halon Alternatives Group (HAG) for fixed fire extinguishing systems.

ECARO-25 SYSTEM DESIGN EXAMPLE

This example walks through the design for a Fike ECARO-25 system protecting a Class A telecommunication facility. This application houses telecommunication switch gear equipment and is equipped with high powered cooling and airflow equipment to keep the switch gear equipment from over heating. The room being protected is 40' x 40' in area with a 10' ceiling and a 2' subfloor.

The first step is to determine the quantity of ECARO-25 required to protect the facility. Both the room and the subfloor will be protected with ECARO-25 because most fires start with an overheated wire or equipment in an equipment rack or subfloor. With the leakage in most subfloors, it is impossible to contain the agent in only in the room. The fire hazard consists of Class-A combustibles, such as cable insulation, and Class-C electrical fires. Per NFPA Standards and the ECARO-25 listings and approvals, a minimum design concentration of 8.0% v/v is used to protect this application. Per NFPA and Fike Design Manuals a flooding factor of .0274 lb/ft³ is multiplied by the room volume in cubic feet to calculate the minimum amount of agent required. The volume of the room is 16,000 ft³ and requires a minimum of 439 pounds of ECARO-25 to achieve a 8.0% design concentration. The volume of the subfloor is 3,200 ft³ and requires a minimum of 88 pounds of ECARO-25.

The most efficient method of protecting this hazard is to use an engineered ECARO-25 system design. An engineered system design allows the designer to use one ECARO-25 container to protect multiple applications and allows for different flow rates at each nozzle in the system. The suggested design practice is to start with a design concentration of 8.2% v/v (factor = .0282 lb/ft³) rather than 8.0% v/v, which simplifies the flow calculation design process and verifies that the minimum quantity of agent is delivered within each protected space. For this application, both the room and subfloor can be protected with one Fike 1000-pound container filled with 542 pounds of ECARO-25 agent. The room will be protected by 452 pounds and the subfloor will be protected by 90 pounds.

Next, the designer should layout the system nozzles in the protected space. As mentioned, the room requires 452 pounds of agent. To minimize turbulence during system discharge, it is recommended that the flow rates of the system nozzles be at or below 20 lbs/sec over a 10-second discharge. In order to keep a balanced system, four nozzles will be placed in the room that will each discharge approximately 113 pounds of ECARO-25 agent. For the subfloor, four nozzles will also be utilized due to excessive obstructions. Even though less than four could protect the subfloor, using four nozzles will ensure adequate agent distribution. Subfloors commonly contain massive amounts of cable and it is not recommended to push the limits of the nozzle coverage in a crowded subfloor. A diagram of the protected enclosure and piping isometric is shown for your reference.

Agent discharge time for this sample problem equals 9.9 seconds in accordance with NFPA Standards and Fike's ECARO-25 UL Listing and FM Approval.

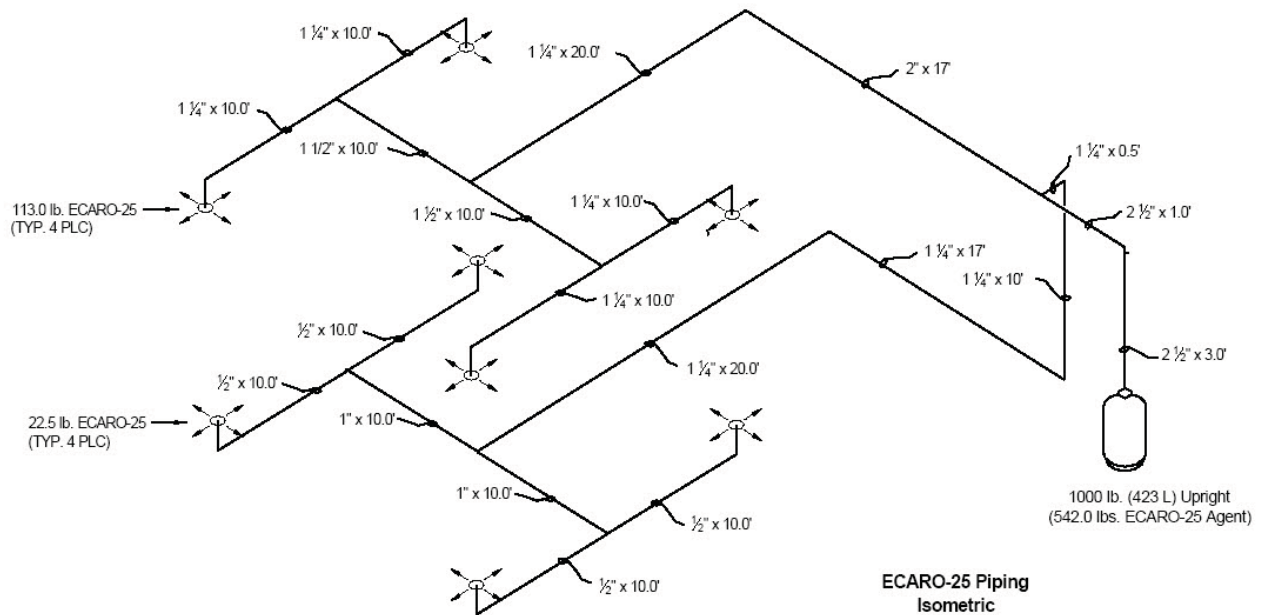
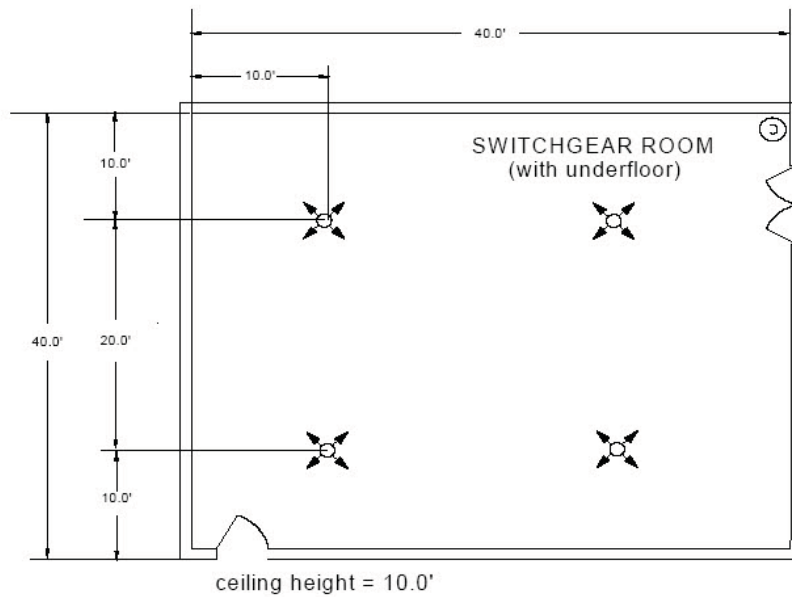

Copyright © Fike Corporation All Rights Reserved.
 DuPont and FE-25 are trademarks or registered trademarks of E.I. DuPont de Nemours and Company.
 Form No. CAAP 040 August, 2010 Specifications are subject to change without notice.